

Sealmatic Delivers B750VN Mechanical Seals With Robust API Plan 65A System For A Refinery Application

The processing of crude oil in refineries is a complex and multi-stage process in which crude oil is transformed into refined, high-quality end products or feed materials for petrochemical industry. Sealing technology for such diverse applications have to meet challenges in various respects; risk of insufficient lubrication and dry running, media with a diversity of physical properties, high and low temperature ranges and the handling of hazardous substances and all other conditions which need to be controlled with absolute reliability. With a comprehensive range of API compliant quality seals and supply systems, Sealmatic is playing a key role towards ensuring the reliability and safety of refinery processes.

Sealmatic continues to demonstrate its engineering excellence in refinery sealing applications with the successful dispatch of type B750VN mechanical seals complete with robust API Plan 65A leakage detection systems for a critical refinery service. This integrated sealing package has been carefully engineered to address the demanding reliability, safety, and environmental expectations of modern hydrocarbon processing facilities, where rotating equipment performance directly influences plant continuity and operational integrity.

As per the above-mentioned operating parameters. The mechanical seals type B750VN single seal was engineered and manufactured specifically for a refinery application. Type B750VN single seal configuration is engineered to provide a robust and stable sealing arrangement suitable for a wide range of hydrocarbon services and demanding operating conditions.

| Operating Parameters Of Type B750VN Single Mechanical Seal For A Refinery Application | | | | | | | | | | | |
|---|----------------------|------|------------|----------|------------------|---|--|--|-----------------|------------------|-----------------------|
| Sr. No. | Mechanical Seal Type | RPM | Media | API Plan | Temperature (°C) | Stuffing Box Pressure (kg/cm ²) | Suction Box Pressure (kg/cm ²) | Discharge Box Pressure (kg/cm ²) | Viscosity (cSt) | Specific Gravity | API 682 Configuration |
| 1 | B750VN (DE) | 2381 | JETA1 FUEL | 11, 65A | 43°C | 2.25 kg/cm ² | 2.25 kg/cm ² | 19 kg/cm ² | 2.2 | 0.804 | 1CW – FL |
| 2 | B750VN (NDE) | 2381 | JETA1 FUEL | 11, 65A | 43°C | 2.25 kg/cm ² | 2.25 kg/cm ² | 19 kg/cm ² | 2.2 | 0.804 | 1CW – FL |

Sealmatic Single Mechanical Seal Type B750VN For A Refinery Application

Sealmatic type B750VN is a robust API 682 4th Edition Category 2 & 3, Type A, Arrangement 1 single cartridge mechanical seal, specifically engineered for critical hydrocarbon and refinery pump applications. Featuring a balanced, multi-spring rotary design, the said mechanical seal delivers highly stable face loading, dependable performance under pressure fluctuations, and consistent sealing reliability across demanding duty cycles. Its independent rotation design and compact cartridge construction make installation simple.

Technical Features Of Type B750VN Single Mechanical Seal

- Robust and compact design
- Standardised components allows efficient stockkeeping
- Extensive applications in the field covering varied temperatures and pressures
- Extensive selection of materials
- Metal parts available in special materials
- Universally applicable both for retrofits or original equipments

Performance Capabilities Of Type B750VN Single Mechanical Seal

- Shaft diameter: d = 20 ... 110 mm (0.79" ... 4.33")
- Pressure: p1 = ... 42 bar (609 PSI)
- Temperature: t = -40 °C ... +176 °C (-40 °F ... +349 °F)*
- Sliding velocity: vg = 23 m/s (75 /s)
- Axial movement: d ≤40 mm ±1.0 mm d ≥40 mm ±1.5 mm

* Engineered up to 260 °C (500 °F) with FFKM (K) secondary seals

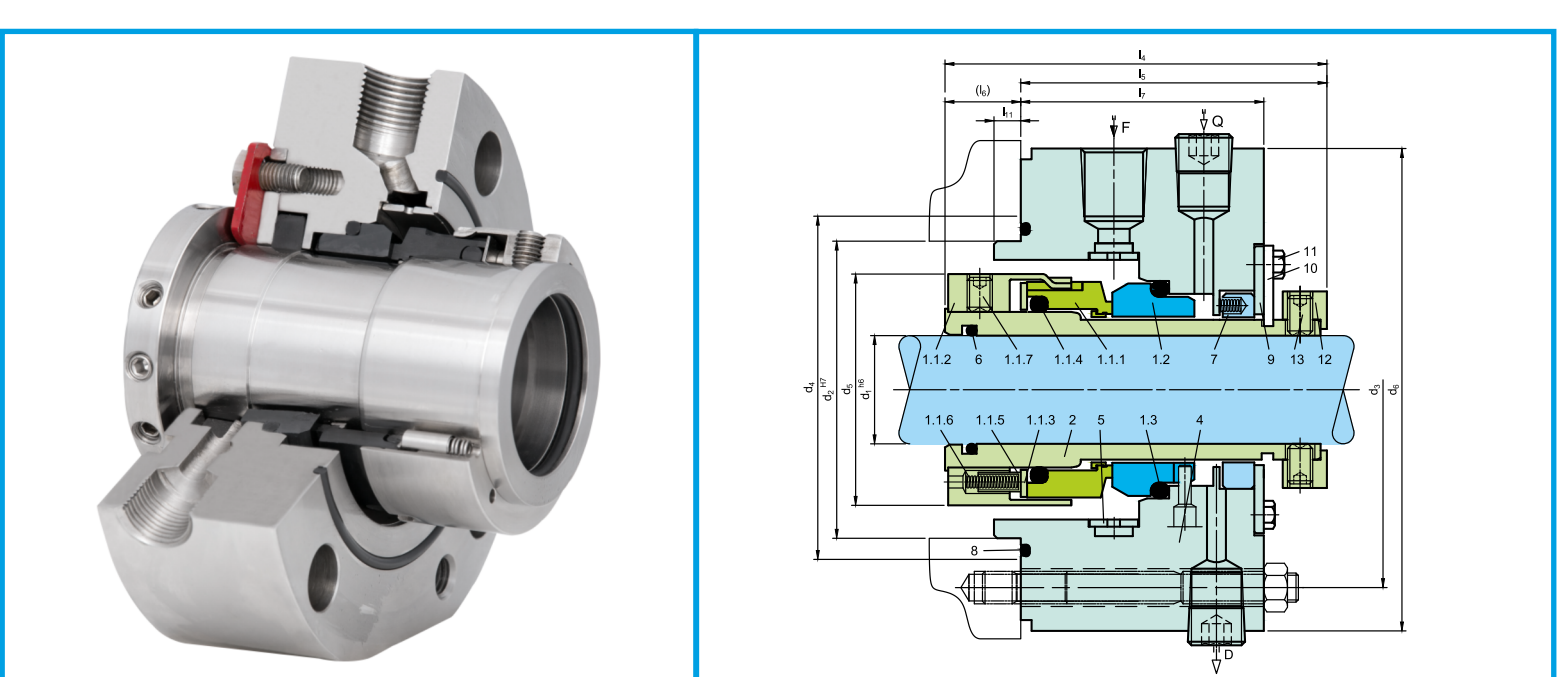

API Plan 65A Seal Support System For Refinery Application

API Plan 65A, as defined in API 682, is a leakage collection and detection system used in mechanical seals. It is specifically designed for applications where liquid leakage is expected to be minimal but must be safely collected and monitored. The said API plan provides an atmospheric leakage collection arrangement, ensuring that any seal leakage is directed to a safe location and detected before it becomes hazardous.

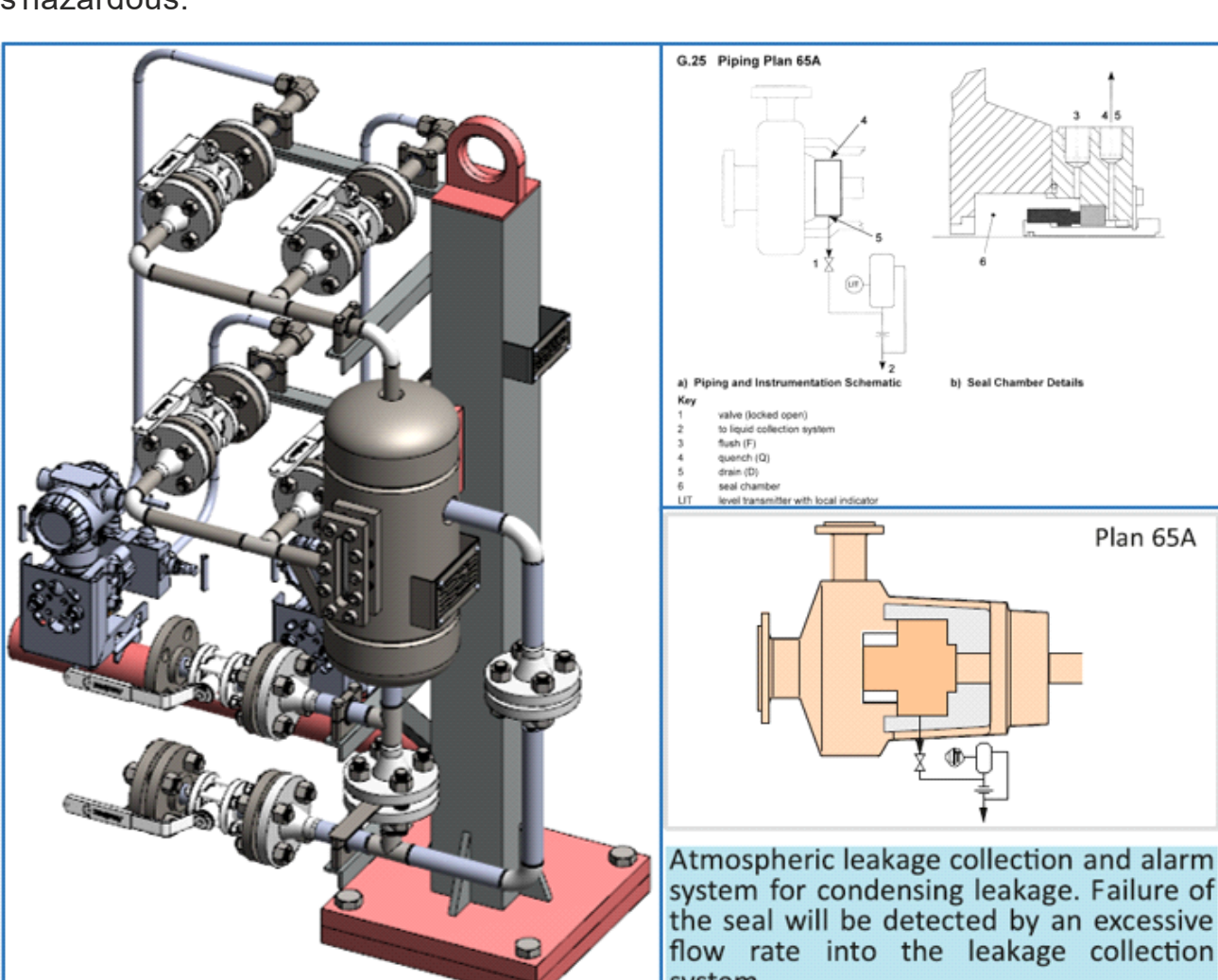

The working principle of API Plan 65A is based on a simple yet highly reliable gravity-driven leakage collection concept. Controlled leakage from the B750VN seal chamber is routed through the drain connection and passed across a calibrated restriction orifice before entering the dedicated collection vessel. During normal operation, the leakage remains within expected limits, allowing the liquid level inside the vessel to remain stable. However, if seal wear, process disturbances, or abnormal operating conditions cause leakage to rise beyond acceptable thresholds, the restriction arrangement creates measurable accumulation within the vessel.

This rising level is continuously monitored through a Differential Pressure Level Transmitter (DPLT), which provides accurate and continuous leakage indication. Once the liquid level exceeds the preset alarm point, the system immediately alerts plant operators, enabling timely corrective action before the seal condition progresses into an equipment failure or process safety concern. In refinery applications handling condensable hydrocarbons, where leakage may not always be visually evident in the initial stages, this early detection capability becomes extremely valuable in preventing escalation and supporting predictive maintenance strategies.

The supplied API Plan 65A systems have been engineered with a refinery grade vessel design to ensure long-term reliability in aggressive service conditions. Each unit consists of a 4 litre SS316L vessel, designed for a design pressure of 36 bar(g), hydrotested at 60 bar(g), and rated for a design temperature of 85°C. Designed and manufactured in accordance with ASME Section VIII Division 1, the vessel offers superior structural integrity, corrosion resistance, and compliance with international pressure vessel standards. The inclusion of precision instrumentation, including DPLT and 5-way manifold valves, further enhances maintainability, calibration accuracy, and dependable field performance.

As refinery operations continue to move toward higher safety standards, stricter environmental compliance and predictive maintenance-driven asset strategies, the integration of Sealmatic type B750VN mechanical seal and API Plan 65A solution stands as a benchmark in engineered sealing excellence for processing applications.

05th May 2026